

SK ID Solutions AS – Certification Practice Statement for EE-GovCA2018

Document information	
Name	Certification Practice Statement for EE-GovCA2018
Version no	1.1
Version history	
Date and version no	Changes
24.03.2025 1.1	Regular review and update of references performed.
01.10.2018 1.0	First public version
Effective from	24.03.2025

1. INTRODUCTION	7
1.1 Overview	7
1.2 Document Name and Identification.....	8
1.3 PKI Participants	8
1.3.1 Certification Authorities	8
1.3.2 Registration Authorities	9
1.3.3 Subscribers	9
1.3.4 Relying Parties	9
1.3.5 Other Participants	9
1.4 Certificate Usage	9
1.5 Policy Administration	10
1.5.1 Organisation Administering the Document	10
1.5.2 Contact Person	10
1.5.3 Person Determining CPS Suitability for the Policy	10
1.5.4 CPS Approval Procedures	10
1.6 Definitions and Acronyms	10
1.6.1 Terminology	10
1.6.2 Acronyms.....	12
2. PUBLICATION AND REPOSITORY RESPONSIBILITIES	13
2.1 Repositories	13
2.2 Publication of Certification Information	13
2.2.1 Publication and Notification Policies.....	13
2.2.2 Items not Published in the Certification Practice Statement.....	13
2.3 Time or Frequency of Publication	13
2.4 Access Controls on Repositories	13
3. IDENTIFICATION AND AUTHENTICATION	14
3.1 Naming.....	14
3.1.1 Types of Names	14
3.1.2 Need for Names to be Meaningful.....	14
3.1.3 Anonymity or Pseudonymity of Subscribers	14
3.1.4 Rules for Interpreting Various Name Forms	14
3.1.5 Uniqueness of Names.....	14
3.1.6 Recognition, Authentication, and Role of Trademarks	14

3.2 Initial Identity Validation.....	14
3.2.1 Method to Prove Possession of Private Key	14
Authentication of Organisation and Domain Identity.....	14
3.2.3 Authentication of Individual Identity	14
Non-Verified Subscriber Information.....	14
3.2.5 Validation of Authority.....	14
3.2.6 Criteria for Interoperation.....	14
3.3 Identification and Authentication for Re-Key Requests	15
3.4 Identification and Authentication for Revocation Request	15
4. CERTIFICATE LIFE-CYCLE OPERATIONAL REQUIREMENTS	16
4.1 Certificate Application	16
4.1.1 Who Can Submit a Certificate Application	16
4.1.2 Enrolment Process and Responsibilities.....	16
4.2 Certificate Application Processing	16
4.2.1 Performing Identification and Authentication Functions	16
4.2.2 Approval or Rejection of Certificate Applications.....	16
4.2.3 Time to Process Certificate Applications.....	16
4.3 Certificate Issuance	16
CA Actions During Certificate Issuance	16
Notification to Subscriber by the CA of Issuance of Certificate	16
4.4 Certificate Acceptance	16
4.4.1 Conduct Constituting Certificate Acceptance	16
4.4.2 Publication of the Certificate by the CA.....	16
4.4.3 Notification of Certificate Issuance by the CA to Other Entities.....	16
4.5 Key Pair and Certificate Usage	17
4.5.1 Subscriber Private Key and Certificate Usage	17
4.5.2 Relying Party Public Key and Certificate Usage.....	17
4.6 Certificate Renewal.....	17
4.7.Certificate Re-Key	17
4.8 Certificate Modification	17
4.8.1 Circumstances for Certificate Modification	17
4.8.2 Who can request Certificate Modification.....	17
4.8.3 Processing Certificate Modification Requests.....	17
4.8.4 Notification of New Certificate Issuance to Subscriber	17

4.8.5 Conduct Constituting Acceptance of Modified Certificate	17
4.8.6 Publication of the Modified Certificate by the CA	17
4.8.7 Notification of Certificate Issuance by the CA to Other Entities.....	17
4.9 Certificate Revocation and Suspension.....	17
4.9.1 Circumstances for Revocation.....	17
4.9.2 Who Can Request Revocation.....	17
4.9.3 Procedure for Revocation Request	17
4.9.4 Revocation Request Grace Period	18
4.9.5 Time Within Which CA Must Process the Revocation Request	18
4.9.6 Revocation Checking Requirements for Relying Parties	18
4.9.7 CRL Issuance Frequency.....	18
4.9.8 Maximum Latency for CRLs.....	18
4.9.9 On-Line Revocation/Status Checking Availability	18
4.9.10 On-Line Revocation Checking Requirements.....	18
4.9.11 Other Forms of Revocation Advertisements Available	18
4.9.12 Special Requirements Related to Key Compromise.....	18
4.9.13 Circumstances for Suspension	18
4.10 Certificate Status Services.....	18
4.10.1 Operational Characteristics.....	18
4.10.2 Service Availability	18
4.10.3 Operational Features	18
4.11 End of Subscription	19
4.12 Key Escrow and Recovery	19
5. FACILITY, MANAGEMENT, AND OPERATIONAL CONTROLS.....	20
6. TECHNICAL SECURITY CONTROLS	21
6.1 Key Pair Generation and Installation	21
6.1.1 Key Pair Generation	21
6.1.2 Private Key Delivery to Subscribers.....	21
6.1.3 Public Key Delivery to Certificate Issuer.....	21
6.1.4 CA Public Key Delivery to Relying Parties.....	21
6.1.5 Key Sizes	21
6.1.6 Public Key Parameters Generation and Quality Checking	21
6.1.7 Key Usage Purposes (as per X.509 v3 Key Usage Field)	21
6.2 Private Key Protection and Cryptographic Module Engineering Controls.....	21

6.2.1 Cryptographic Module Standards and Controls.....	21
6.2.2 Private Key (n out of m) Multi-Person Control	21
6.2.3 Private Key Escrow	21
6.2.4 Private Key Backup.....	21
6.2.5 Private Key Archival.....	21
6.2.6 Private Key Transfer Into or From a Cryptographic Module.....	21
6.2.7 Private Key Storage on Cryptographic Module	22
6.2.8 Method of Activating Private Key	22
6.2.9 Method of Deactivating Private Key	22
6.2.10 Method of Destroying Private Key	22
6.2.11 Cryptographic Module Rating	22
6.3 Other Aspects of Key Pair Management.....	22
6.4 Activation Data	22
6.4.1 Activation Data Generation and Installation.....	22
6.4.2 Activation Data Protection	22
6.4.3 Other Aspects of Activation Data.....	22
6.5 Computer Security Controls.....	22
6.6 Life Cycle Technical Controls.....	22
6.7 Network Security Controls.....	22
6.8 Time-Stamping.....	22
7. CERTIFICATE, CRL, AND OCSP PROFILES	23
7.1 Certificate Profile	23
7.2 CRL Profile	23
7.3 OCSP Profile	23
8. COMPLIANCE AUDIT AND OTHER ASSESSMENTS.....	24
9. OTHER BUSINESS AND LEGAL MATTERS.....	25
9.1 Fees	25
9.2 Financial Responsibility.....	25
9.2.1 Insurance Coverage.....	25
9.2.2 Other Assets	25
9.2.3 Insurance or Warranty Coverage for End-Entities	25
9.3 Confidentiality of Business Information	25
9.4 Privacy of Personal Information	25
9.5 Intellectual Property Rights	25

9.6 Representations and Warranties	25
9.6.1 CA Representations and Warranties	25
9.6.2 RA Representations and Warranties	25
9.6.3 Subscriber Representations and Warranties	25
9.6.4 Relying Party Representations and Warranties	25
9.6.5 Representations and Warranties of Other Participants	26
9.7 Disclaimers of Warranties	26
9.8 Limitations of Liability	26
9.9 Indemnities	26
9.10 Term and Termination	26
9.10.1 Term	26
9.10.2 Termination	26
9.10.3 Effect of Termination and Survival	26
9.11 Individual Notices and Communications with Participants	26
9.12 Amendments	26
9.12.1 Procedure for Amendment	26
9.12.2 Notification Mechanism and Period	26
9.12.3 Circumstances Under Which OID Must be Changed	26
9.13 Dispute Resolution Provisions	26
9.14 Governing Law	26
9.15 Compliance with Applicable Law	26
9.16 Miscellaneous Provisions	27
9.16.1 Entire Agreement	27
9.16.2 Assignment	27
9.16.3 Severability	27
9.16.4 Enforcement (Attorneys' Fees and Waiver of Rights)	27
9.16.5 Force Majeure	27
9.17 Other Provisions	27
REFERENCES	28

1. INTRODUCTION

SK ID Solutions AS (SK) was founded on March 26th 2001. The owners of the limited liability company are AS Swedbank, AS SEB Pank and Telia Eesti AS. The principal activities of SK are offering trust services and related technical solutions in the Baltic region. These services guarantee secure and verified electronic communication with public institutions as well as businesses in everyday life.

Inspired by the ETSI EN 319 400 series, SK has divided its documentation into three parts:

SK PS [1] describes general practices common to all trust services;

Certification Practice Statements and Time-Stamping Practice Statements describe parts that are specific to each Subordinate CA or Time-Stamping Unit;

Technical Profiles are in separate documents.

Pursuant to the IETF RFC 3647 [2] this CPS is divided into nine parts. To preserve the outline specified by RFC 3647 [2], section headings that do not apply have the statement "Not applicable". References to SK PS [1] and Certificate Profile documents [3] are included where applicable.

1.1 Overview

This CPS describes the practices used to comply with "Requirements for issuing and managing the EE-GovCA2018 root certificate" (hereinafter referred to as CP) [4].

This CPS covers operation of EE-GovCA2018 to issue certificate for intermediate CA ESTEID2018.

In case of conflicts the documents are considered in the following order (prevailing one first):

- CP [4];
- this CPS.

The relation between Root CA and Subordinate CA is shown on the following figure:

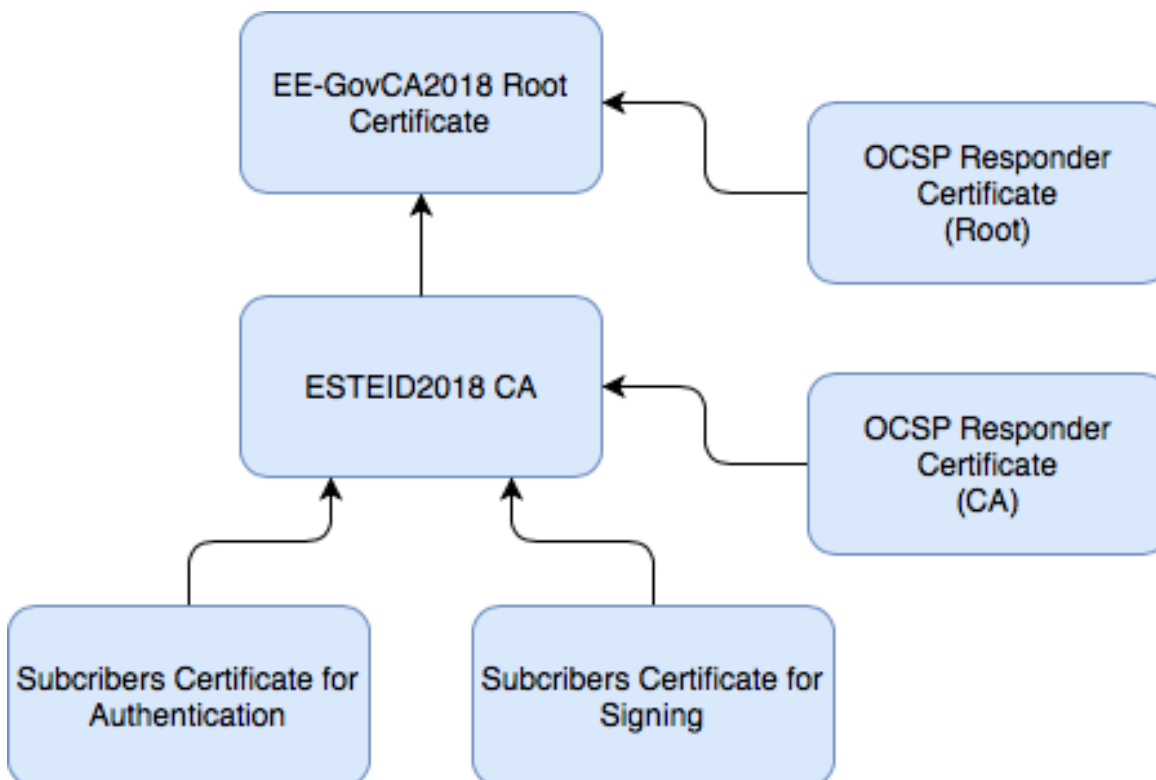

EE-GovCA2018 is the issuing CA.

1.2 Document Name and Identification

This document is called “SK ID Solutions AS – Certification Practice Statement for EE-GovCA2018.” This is the first version of the document.

1.3 PKI Participants

1.3.1 Certification Authorities

SK operates as a CA.

The certification service of SK covers all procedures described in this CPS related to lifecycle of keypairs and certificates.

SK does not use third parties to issue and maintain certificates issued by EE-GovCA2018.

EE-GovCA2018 is identified by the following certificate:

Certificate:

Data:

Version: 3 (0x2)

Serial Number:

30:b3:b0:95:7a:11:d2:81:5b:8f:9d:a7:99:1b:27:7b

Signature Algorithm: ecdsa-with-SHA512

Issuer: C=EE, O=SK ID Solutions AS/2.5.4.97=NTREE-10747013, CN=EE-GovCA2018

Validity

Not Before: Sep 5 09:11:03 2018 GMT

Not After : Sep 5 09:11:03 2033 GMT

Subject: C=EE, O=SK ID Solutions AS/2.5.4.97=NTREE-10747013, CN=EE-GovCA2018

Subject Public Key Info:

Public Key Algorithm: id-ecPublicKey

Public-Key: (521 bit)

pub:

04:00:c7:1b:fd:d9:80:71:5a:3f:6f:66:b3:10:f4:ba:09:f5:bb:7c:40:36:2a:e1:ca:0b:9d:c3:ed:28:
55:36:f2:f3:e1:05:23:09:d4:d7:8d:db:3f:e2:ef: 7d:8d:4a:18:11:07:9c:96:e5:55:cc:c9:60:10:94:
75:9e:43:76:78:ea:cb:01:96:31:3e:3c:06:e4:78:88:d6:26:44:c9:6f:50:29:57:5e:12:0c:af:87:35:
96:4c:d1:c6:8d:5d:c7:75:94:6f:ec:bf:68:e3:9d:f7:3e:d2:40:ca:a2:6a:f4:e4:ec:ea:68:ec:ab:01:
57:8c:7e:3d:6d:f6:7a:08:69:b3:50:9b:07

ASN1 OID: secp521r1

X509v3 extensions:

X509v3 Basic Constraints: critical

CA:TRUE, pathlen:1

X509v3 Key Usage: critical

Certificate Sign, CRL Sign

X509v3 Extended Key Usage: critical

OCSP Signing, TLS Web Client Authentication, E-mail Protection, TLS Web Server Authentication

X509v3 Subject Key Identifier:

7E:29:56:E7:34:92:78:4E:77:E1:6F:2E:33:2A:98:71:C1:FD:34:9F

X509v3 Authority Key Identifier:

keyid:7E:29:56:E7:34:92:78:4E:77:E1:6F:2E:33:2A:98:71:C1:FD:34:9F

X509v3 Certificate Policies:

Policy: 0.4.0.2042.1.2

Policy: 0.4.0.194112.1.2

Policy: 1.3.6.1.4.1.51361.1.1.1

CPS: <https://www.sk.ee/CPS>

Policy: 1.3.6.1.4.1.51361.1.1.2

Policy: 1.3.6.1.4.1.51455.1.1.1

Policy: 1.3.6.1.4.1.51361.1.1.5

Policy: 1.3.6.1.4.1.51361.1.1.6

Policy: 1.3.6.1.4.1.51361.1.1.7

Policy: 1.3.6.1.4.1.51361.1.1.3

Policy: 1.3.6.1.4.1.51361.1.1.4

Policy: 1.3.6.1.4.1.51361.1.1.8

Policy: 1.3.6.1.4.1.51361.1.1.9

Policy: 1.3.6.1.4.1.51361.1.1.10

Policy: 1.3.6.1.4.1.51361.1.1.11
 Policy: 1.3.6.1.4.1.51361.1.1.12
 Policy: 1.3.6.1.4.1.51361.1.1.13
 Policy: 1.3.6.1.4.1.51361.1.1.14
 Policy: 1.3.6.1.4.1.51361.1.1.15
 Policy: 1.3.6.1.4.1.51361.1.1.16
 Policy: 1.3.6.1.4.1.51361.1.1.17
 Policy: 1.3.6.1.4.1.51361.1.1.18
 Policy: 1.3.6.1.4.1.51361.1.1.19
 Policy: 1.3.6.1.4.1.51361.1.1.20
 Policy: 1.3.6.1.4.1.51455.1.1.2
 Policy: 1.3.6.1.4.1.51455.1.1.3
 Policy: 1.3.6.1.4.1.51455.1.1.4
 Policy: 1.3.6.1.4.1.51455.1.1.5
 Policy: 1.3.6.1.4.1.51455.1.1.6
 Policy: 1.3.6.1.4.1.51361.10.1
 CPS: <https://www.sk.ee/CPS>

qcStatements:

0

0.....F..

Signature Algorithm: ecDSA-with-SHA512

30:81:88:02:42:01:93:af:7c:12:a7:ad:63:d4:ed:e8:7c:0e:e7:40:9f:cd:d2:08:8c:a9:a5:7c:22:37:e3:12:9d:53:b2:7e:
 c3:3d:6d:35:5b:b6:b4:72:70:12:17:6c:1f:47:bd:da:2f:7a:f6:c4:43:a7:54:4d:3e:55:61:e1:71:49:cc:8d:e8:40:54:02:42:01:95:c6:67:2e:
 :56:7b:32:ec:d5:2c:70:36:74:7a:bc:28:be:66:c5:3a:c3:71:10:b0:80:37:13:52:5b:1e:71:32:ac:c4:22:15:7c:e3:aa:29:c6:ed:74:50:50:
 c8:04:13:f3:91:b0:5e:9c:be:21:fa:0f:d6:53:b9:46:ef:c7:c8:84

-----BEGIN CERTIFICATE-----

MIIe+DCCBFmgAwlBAGlQMLOwlXoR0oFbj52nmRsnezAKBggqhkJOPQQDBDBaMQswCQYDVQGEwJFRTEbMBkGA1UECgwSU0sgSUQGU29sdXRpb25zIEFTMRcwFQYDVQRhDA5OVFJFRS0xMDc0NzAxMzEVMzEwMDEwWjELMAkGA1UEBhMCRUUxGzAZBgNVBAoMEINLEIEIFNvbHV0aW9ucyBBUzEXMBUGA1UEYQwOTIRSRUUtMTA3NDcwMTMxFTATBgNVBAMMDEVFLUdvdkNBmJAxODCBmzAQBgcqhkJOPQIBBgUrgQAIAwOBhgAEMcb/dmAcVo/b2azEPS6CfW7fEA2KuHKC53D7ShVnVlZ4QUjCdTXjds/4u99jUoYEQecluVvzMlgEJR1nkN2eOrLAZYxPjwG5Hil1iZEyW9QKVdeEgyvhzWWTNHGjV3HdZrV7L9o4533PtJAyqJq9OTs6mjsqwFXjH49bfZ6CGmzUJsHo4lCvDCCArgwEgYDVR0TAQH/BAgwBgEB/wlBATAOBgNVHQ8BAf8EBAMCAQYwNAYDVR0IAQH/BCowKAYIKwYBBQUHAwGCCsGAQUFBwMCBggrBgEFBQcDBAYIKwYBBQUHAwEwHQYDVR0OBBYEFH4pVuc0knhOd+FvLjMqrmHhB/TSfMIB8GA1UdIwQYMBaAFH4pVuc0knhOd+FvLjMqrmHhB/TSfMIICAAyDVR0gBIIIB9zCCAfmwCAYGBACPegECMAkGBWQAI+xAQIwMgYLKwYBBAGDkSEBAQEwIzAhBgggrBgEFBQcCARYVaHR0cHM6Ly93d3cuc2suZWUvQ1BTMA0GCysGAQQB5EhAQECMA0GCysGAQQB5F/AQEBMA0GCysGAQQB5EhAQEFMA0GCysGAQQB5EhAQEGMA0GCysGAQQB5EhAQEHA0GCysGAQQB5EhAQEDMA0GCysGAQQB5EhAQEEMA0GCysGAQQB5EhAQEIMA0GCysGAQQB5EhAQEJMA0GCysGAQQB5EhAQEKMA0GCysGAQQB5EhAQELMA0GCysGAQQB5EhAQEMMA0GCysGAQQB5EhAQENMA0GCysGAQQB5EhAQEOMA0GCysGAQQB5EhAQEPMA0GCysGAQQB5EhAQEQMA0GCysGAQQB5EhAQERMA0GCysGAQQB5EhAQESMA0GCysGAQQB5EhAQETMA0GCysGAQQB5EhAQEU0GCysGAQQB5F/AQECMA0GCysGAQQB5F/AQEDMA0GCysGAQQB5F/AQEEMA0GCysGAQQB5F/AQEFMA0GCysGAQQB5F/AQEGMA0GCysGAQQB5EhCgEwIzAhBgggrBgEFBQcCARYVaHR0cHM6Ly93d3cuc2suZWUvQ1BTMBGcCCsGAQUFBwEDBawwCjAIBgYEAI5GAQEwCgYIKoZlZj0EAWQDgYwAMIGIAkIBk698EquetY9Tt6HwO50CfzdlljKmlfCI34xKdU7J+wz1tNVu2tHJwEhdsH0e92i969sRDP1RNPVh4XFJzI3oQFQCQgGVxmcuVnSy7NUscDZ0erwovmbFOsNxELCANxNSWx5xMqzEIHV846opxu10UFDIBBPzkbBenL4h+g/WU7IG78flhA===

1.3.2 Registration Authorities

Not applicable.

1.3.3 Subscribers

SK is the Subscriber in the context of this CPS.

1.3.4 Relying Parties

A Relying Party is a natural or legal person who takes a decision relying on the certificate issued by SK.

1.3.5 Other Participants

Not applicable.

1.4 Certificate Usage

Only subordinate CA and servicing certificates are issued according to this CPS.

1.5 Policy Administration

1.5.1 Organisation Administering the Document

This CPS is administered by SK.

SK ID Solutions AS

Registry code 10747013

Pärnu mnt 141, 11314 Tallinn

Tel +372 610 1880

Email: info@skidsolutions.eu

<http://www.skidsolutions.eu>

1.5.2 Contact Person

Head of eID and Trust Services

Email: info@skidsolutions.eu

1.5.3 Person Determining CPS Suitability for the Policy

Not applicable.

1.5.4 CPS Approval Procedures

Amendments which do not change the meaning of the CPS, such as corrections of misspellings, translation and updating of contact details, are documented in the Versions and Changes section of the present document and the fraction part of the document version number is enlarged.

In case of substantial changes, the new CPS version is clearly distinguishable from the previous ones. The new version bears a serial number enlarged by one. The amended CPS along with the enforcement date is published electronically on SK's website.

Amendments to this CPS are coordinated with PBGB.

All amendments are to be approved by the head of eID and trust services and the amended CPS is enforced by the CEO.

1.6 Definitions and Acronyms

1.6.1 Terminology

In this CPS the following terms have the following meaning.

Term	Definition
Certificate Policy	A set of rules that indicates applicability of a specific Certificate to a particular community and/or Public Key Infrastructure implementation with common security requirements.
Certification Practice Statement	One of several documents forming the governance framework in which Certificates are created, issued, managed, and used.
Certificate Profile	Document that determines the profile and minimum requirements for the Certificate.
Certificate Revocation List	A list of invalid (revoked, suspended) certificates.

Term	Definition
Certification Service	Issuing certificates, managing suspension, termination of suspension, revocation, modification and re-key.
Directory Service	Certificate validity information publication service.
Certificate	Public Key, together with additional information, laid down in the Certificate Profile [3], rendered unforgeable via encipherment using the Private Key of the Certificate Authority which issued it.
Private Key	The key of a key pair that is kept secret by the holder of the key pair, and that is used to create digital signatures and/or to decrypt electronic records or files that were encrypted with the corresponding public key.
Public Key	The key pair that may be publicly disclosed by the holder of corresponding private key and that is used by Relying Party to verify digital signatures created with the holder's corresponding private key and/or to encrypt messages so that they can be decrypted only with the holder's corresponding private key.
Relying Party	Entity that relies upon the information contained within a certificate.
eIDAS Regulation	Regulation (EU) No 910/2014 of the European Parliament and of the Council of 23 July 2014 on electronic identification and trust services for electronic transactions in the internal market and repealing Directive 1999/93/EC
OCSP	Protocol for checking certificate validity
Root CA	Highest level certification authority, whose certificate is bundled with application software and that issues certificates to subordinate CA-s.
SK CA	Certification authority of SK, whose certificate is signed by Root CA or another subordinate CA.
Supervisory body	An institution, designated by Member State to carry out supervision according to eIDAS Regulation [5] over trust services and trust service providers on the territory of Member State.
Trust Service	Described in eIDAS Regulation [5] as an electronic service offered for a fee and that covers <ul style="list-style-type: none"> - creation, verification and validity confirmation of electronic signatures, electronic seals or electronic time stamps, electronic registration services and certificates related to these services; - creation, verification and validity confirmation of certificates for website authentication - maintaining the certificates related to electronic signatures, stamps or services related to them
Trust Service Provider	Organisation that provides at least one Trust Service

1.6.2 Acronyms

Acronym	Definition
CA	Certification Authority
CP	Certificate Policy [4]
CPS	Certification Practice Statement for EE-GovCA2018
CRL	Certificate Revocation List
HSM	Hardware Security Module
PBGB	Police and Border Guard Board
SK	SK ID Solutions AS, provider of the certification services
SK PS	SK ID Solutions AS Trust Services Practice Statement [1]

2. PUBLICATION AND REPOSITORY RESPONSIBILITIES

2.1 Repositories

Refer to clause 2.1 of SK PS [1].

2.2 Publication of Certification Information

Refer to clause 2.2 of SK PS [1].

2.2.1 Publication and Notification Policies

This CPS is published on SK's website: <https://www.skidsolutions.eu/resources/certification-practice-statement/>.

2.2.2 Items not Published in the Certification Practice Statement

Refer to clause 9.3.1 of SK PS [1].

2.3 Time or Frequency of Publication

Refer to clause 1.5.4 of SK PS [1].

2.4 Access Controls on Repositories

Refer to clause 2.4 of SK PS [1].

3. IDENTIFICATION AND AUTHENTICATION

3.1 Naming

3.1.1 Types of Names

Types of names assigned to the Subscriber are described in the Certificate Profile [6].

3.1.2 Need for Names to be Meaningful

Meanings of names on different fields of the certificate are described in the Certificate Profile [3].

3.1.3 Anonymity or Pseudonymity of Subscribers

Not allowed.

3.1.4 Rules for Interpreting Various Name Forms

Rules for interpreting various name forms are described in the Certificate Profile [6].

3.1.5 Uniqueness of Names

SK guarantees that multiple certificates with identical distinguished names are not valid at the same time.

3.1.6 Recognition, Authentication, and Role of Trademarks

Not allowed

3.2 Initial Identity Validation

3.2.1 Method to Prove Possession of Private Key

Possession of Private Key is guaranteed by internal procedures of SK. Procedures are carried out by persons named by CEO of SK and observed by the representative of PBGB and an external auditor.

Authentication of Organisation and Domain Identity

Not applicable.

3.2.3 Authentication of Individual Identity

CEO of SK defines a commission of at least 4 persons to carry out key generation and certification procedures. The head of commission is nominated also by CEO.

An independent auditor identifies the representative of PBGB and personnel carrying out the procedure and verifies their authorisation.

Non-Verified Subscriber Information

Not allowed.

3.2.5 Validation of Authority

CEO of SK nominates personnel carrying out the procedures of key generation and certification.

Director General of PBGB nominates the representative of PBGB observing the key generation and certification procedures.

3.2.6 Criteria for Interoperation

EE-GovCA2018 does not cross-certify other Root CA-s.

3.3 Identification and Authentication for Re-Key Requests

Not applicable.

3.4 Identification and Authentication for Revocation Request

Refer to clause 3.2.3 of this CPS.

4. CERTIFICATE LIFE-CYCLE OPERATIONAL REQUIREMENTS

4.1 Certificate Application

4.1.1 Who Can Submit a Certificate Application

CEO of SK approves certificate applications.

4.1.2 Enrolment Process and Responsibilities

CEO of SK approves the application for key generation and certification and nominates list of persons to carry out the procedure, contents, time and place of the procedure.

CEO of SK nominates at least 4 persons to carry out the key generation and certification procedures.

An independent external auditor and the representative of PBGB are nominated by CEO of SK and Director General of PBGB respectively to observe the key generation and certification procedures.

4.2 Certificate Application Processing

4.2.1 Performing Identification and Authentication Functions

Refer to clause 3.2.3 of this CPS.

4.2.2 Approval or Rejection of Certificate Applications

All certificate applications that have not been enforced with the directive issued by CEO of SK are rejected.

4.2.3 Time to Process Certificate Applications

CEO of SK defines the time to process the application.

4.3 Certificate Issuance

CA Actions During Certificate Issuance

The certificate is issued manually from an off-line part of SK's information system based on the regulation of CEO of SK. The procedure is carried out by the commission mandated by CEO.

The certificate is valid from the moment of issuance.

Only one intermediate CA certificate issued by EE-GovCA2018 can be valid at any point in time.

After issuance of a certificate, a new CRL is issued and a fresh backup of the database of EE-GovCA2018 is made.

Notification to Subscriber by the CA of Issuance of Certificate

The procedure is documented in a way that shows the activities done and the certificate issued. The document on the issuance is signed by members of the commission.

4.4 Certificate Acceptance

4.4.1 Conduct Constituting Certificate Acceptance

A member of the commission verifies that the issued certificate is correct.

4.4.2 Publication of the Certificate by the CA

The certificate is published on webpage of SK: <https://www.skidsolutions.eu/resources/certificates/>.

4.4.3 Notification of Certificate Issuance by the CA to Other Entities

Refer to clause 4.4.2 of this CPS.

4.5 Key Pair and Certificate Usage

4.5.1 Subscriber Private Key and Certificate Usage

The Subscriber is required to use the Private Key and the certificate in accordance with CPS of the CA to be certified.

4.5.2 Relying Party Public Key and Certificate Usage

Relying Party is required to use the Subscriber's Public Key and the certificate in accordance with CPS of the CA to be certified.

4.6 Certificate Renewal

Not applicable.

4.7. Certificate Re-Key

Not applicable.

4.8 Certificate Modification

4.8.1 Circumstances for Certificate Modification

Certificate Modification is allowed to correct mistakes in previous certificate.

4.8.2 Who can request Certificate Modification

CEO of SK can request Certificate Modification.

4.8.3 Processing Certificate Modification Requests

Refer to clause 4.2 of this CPS.

4.8.4 Notification of New Certificate Issuance to Subscriber

Refer to clause 4.3.2 of this CPS.

4.8.5 Conduct Constituting Acceptance of Modified Certificate

Refer to clause 4.4.1 of this CPS.

4.8.6 Publication of the Modified Certificate by the CA

Refer to clause 4.4.2 of this CPS.

4.8.7 Notification of Certificate Issuance by the CA to Other Entities

Refer to clause 4.4.3 of this CPS.

4.9 Certificate Revocation and Suspension

4.9.1 Circumstances for Revocation

Refer to the CP [4].

4.9.2 Who Can Request Revocation

Request for revocation is submitted to CEO of SK in a signed form.

4.9.3 Procedure for Revocation Request

The application for revocation can be submitted only to CEO of SK.

The application is checked for correctness and validity according to presented evidences and other available information.

After revoking the certificate SK issues immediately a new CRL which contains the serial number of the revoked certificate.

4.9.4 Revocation Request Grace Period

Not applicable.

4.9.5 Time Within Which CA Must Process the Revocation Request

SK will process the revocation request within 5 working days after receiving the application.

4.9.6 Revocation Checking Requirements for Relying Parties

Relying Party must verify the validity of a certificate before trusting it.

4.9.7 CRL Issuance Frequency

CRL is issued once every 90 days, with the value of the nextUpdate field set to 97 days after issuance of CRL.

4.9.8 Maximum Latency for CRLs

CRL is published no later than 1 working day after issuance.

4.9.9 On-Line Revocation/Status Checking Availability

Refer to clause 4.10.1 of this CPS.

4.9.10 On-Line Revocation Checking Requirements

Relying Party is obliged to check the status of a certificate.

4.9.11 Other Forms of Revocation Advertisements Available

Information about revocation of a certificate can be requested by e-mail at info@skidsolutions.eu or by phone +372 6101880.

4.9.12 Special Requirements Related to Key Compromise

A security incident must be opened in case of key compromise.

4.9.13 Circumstances for Suspension

Not applicable.

4.10 Certificate Status Services

4.10.1 Operational Characteristics

SK offers CRL and OCSP services for checking certificate status. Services are accessible over HTTP protocol. The status of a certificate can be verified using OCSP protocol at <http://aia.sk.ee/ee-govca2018> and using CRL at <http://c.sk.ee/EE-GovCA2018.crl>. The URLs of the services are included in the certificates on the CRL Distribution Point (CDP) and Authority Information Access (AIA) fields respectively in accordance with the Certificate Profile [6].

4.10.2 Service Availability

SK ensures availability of Certificate Status Services 24 hours a day, 7 days a week with a minimum of 99.44% availability overall per year with a scheduled downtime that does not exceed 0.28% annually.

4.10.3 Operational Features

None.

4.11 End of Subscription

Not applicable.

4.12 Key Escrow and Recovery

Not applicable.

5. FACILITY, MANAGEMENT, AND OPERATIONAL CONTROLS

Refer to clause 5 of SK PS [1].

6. TECHNICAL SECURITY CONTROLS

6.1 Key Pair Generation and Installation

Refer to clause 6.1 of SK PS [1].

6.1.2 Key Pair Generation

Refer to clause 6.1.1 of SK PS [1].

The Director General of PBGB nominates the representative of PBGB observing the key generation procedure.

6.1.2 Private Key Delivery to Subscribers

Not applicable.

6.1.3 Public Key Delivery to Certificate Issuer

The public key is delivered using removable media and the auditor verifies its integrity.

6.1.4 CA Public Key Delivery to Relying Parties

Refer to clause 6.1.4 of SK PS [1].

6.1.5 Key Sizes

Key size is 521 bits with an ECC algorithm used.

6.1.6 Public Key Parameters Generation and Quality Checking

Refer to clause 6.1.6 of SK PS [1].

6.1.7 Key Usage Purposes (as per X.509 v3 Key Usage Field)

Key usage purposes are described in the Certificate Profile [6].

6.2 Private Key Protection and Cryptographic Module Engineering Controls

6.2.1 Cryptographic Module Standards and Controls

Refer to clause 6.2.1 of SK PS [1].

6.2.2 Private Key (n out of m) Multi-Person Control

Refer to clause 6.2.2 of SK PS [1].

The access to Private Key is divided between PBGB and SK. For activation of the Private Key the presence of the representative of PBGB is required.

6.2.3 Private Key Escrow

Refer to clause 6.2.3 of SK PS [1].

6.2.4 Private Key Backup

Refer to clause 6.2.4 of SK PS [1].

6.2.5 Private Key Archival

Refer to clause 6.2.5 of SK PS [1].

6.2.6 Private Key Transfer Into or From a Cryptographic Module

Refer to clause 6.2.6 of SK PS [1].

6.2.7 Private Key Storage on Cryptographic Module

Refer to clause 6.2.7 of SK PS [1].

6.2.8 Method of Activating Private Key

Refer to clause 6.2.8 of SK PS [1].

6.2.9 Method of Deactivating Private Key

Refer to clause 6.2.9 of SK PS [1].

6.2.10 Method of Destroying Private Key

Refer to clause 6.2.10 of SK PS [1].

6.2.11 Cryptographic Module Rating

Refer to clause 6.2.11 of SK PS [1].

6.3 Other Aspects of Key Pair Management

Refer to clause 6.3 of SK PS [1].

6.4 Activation Data

6.4.1 Activation Data Generation and Installation

Refer to clause 6.4.1 of SK PS [1].

6.4.2 Activation Data Protection

Refer to clause 6.4.2 of SK PS [1].

Activation data is divided between PBGB and SK one share of the activation data is held by PBGB and the other by SK. PBGB and SK apply necessary security measures to keep their share of the activation data under their control.

6.4.3 Other Aspects of Activation Data

Refer to clause 6.4.2 of SK PS [1].

6.5 Computer Security Controls

Refer to clause 6.5 of SK PS [1].

6.6 Life Cycle Technical Controls

Refer to clause 6.6 of SK PS [1].

6.7 Network Security Controls

Refer to clause 6.7 of SK PS [1].

6.8 Time-Stamping

Refer to clause 6.8 of SK PS [1].

7. CERTIFICATE, CRL, AND OCSP PROFILES

7.1 Certificate Profile

The certificate profile is described in the Certificate Profile [3], published in SK's public information repository <https://www.skidsolutions.eu/resources/profiles/> .

7.2 CRL Profile

The CRL profile is described in the Certificate Profile [3], published in SK's public information repository <https://www.skidsolutions.eu/resources/profiles/> .

7.3 OCSP Profile

The OCSP profile is described in the Certificate Profile [3], published in SK's public information repository <https://www.skidsolutions.eu/resources/profiles/> .

8. COMPLIANCE AUDIT AND OTHER ASSESSMENTS

Refer to chapter 8 of SK PS [1].

9. OTHER BUSINESS AND LEGAL MATTERS

9.1 Fees

Not applicable.

9.2 Financial Responsibility

9.2.1 Insurance Coverage

Refer to clause 9.2.1 of SK PS [1].

9.2.2 Other Assets

Not applicable.

9.2.3 Insurance or Warranty Coverage for End-Entities

Refer to clause 9.2.1 of SK PS [1].

9.3 Confidentiality of Business Information

Refer to clause 9.3 of SK PS [1].

9.4 Privacy of Personal Information

Refer to clause 9.4 of SK PS [1].

9.5 Intellectual Property Rights

Refer to clause 9.5 of SK PS [1].

9.6 Representations and Warranties

9.6.1 CA Representations and Warranties

Refer to clause 9.6.1 of SK PS [1].

SK ensures that:

- the certification keys are protected by HSM and are under sole control of SK;
- in case of compromise of certification keys all issued certificates will be revoked;
- all the activated certification keys are on the territory of the Republic of Estonia.
- the certification keys used in the supply of the certification service are activated on the basis of shared control.

9.6.2 RA Representations and Warranties

Not applicable.

9.6.3 Subscriber Representations and Warranties

Not Applicable.

9.6.4 Relying Party Representations and Warranties

Refer to clause 9.6.4 of SK PS [1].

A Relying Party studies the risks and liabilities related to acceptance of the Certificate. The risks and liabilities have been set out in this CPS.

9.6.5 Representations and Warranties of Other Participants

Not applicable.

9.7 Disclaimers of Warranties

Refer to clause 9.7 of SK PS [1].

9.8 Limitations of Liability

Refer to clause 9.8 of SK PS [1].

9.9 Indemnities

Not applicable.

9.10 Term and Termination

9.10.1 Term

Refer to clause 1.5.4 of this CPS.

9.10.2 Termination

Refer to clause 9.10.2 of SK PS [1].

9.10.3 Effect of Termination and Survival

SK communicates the conditions and effect of the termination of this CPS via its public repository. The communication specifies which provisions survive termination.

At a minimum, all responsibilities related to protecting confidential information, also maintenance of SK archives for determined period and logs survive termination.

Termination of this CPS cannot occur before termination actions described in clause 5.8 of this CPS.

9.11 Individual Notices and Communications with Participants

Refer to clause 9.11 of SK PS [1].

9.12 Amendments

9.12.1 Procedure for Amendment

Refer to clause 1.5.4 of this CPS.

9.12.2 Notification Mechanism and Period

Refer to clause 2.2.1 of this CPS.

9.12.3 Circumstances Under Which OID Must be Changed

Not applicable.

9.13 Dispute Resolution Provisions

Refer to clause 9.13 of SK PS [1].

9.14 Governing Law

This CPS is governed by the jurisdictions of the European Union and Estonia.

9.15 Compliance with Applicable Law

SK ensures compliance with all requirements to comply with laws to protect data against loss, destroying or forging, and the following requirements:

- eIDAS - Regulation (EU) No 910/2014 of the European Parliament and of the Council of 23 July 2014 on electronic identification and trust services for electronic transactions in the internal market and repealing Directive 1999/93/EC [5];
- Relevant European standards:
- ETSI EN 319 401 Electronic Signatures and Infrastructures (ESI): General Policy Requirements for Trust Service Providers [6];
- ETSI EN 319 411-1 Electronic Signatures and Infrastructures (ESI); Policy and Security requirements for Trust Service Providers issuing certificates; Part 1: General requirements [7];
- ETSI EN 319 411-2 Electronic Signatures and Infrastructures (ESI); Policy and security requirements for Trust Service Providers issuing certificates; Part 2: Policy requirements for certification authorities issuing qualified certificates [8].

9.16 Miscellaneous Provisions

9.16.1 Entire Agreement

Not applicable.

9.16.2 Assignment

Any entities operating under this CPS may not assign their rights or obligations without the prior written consent of SK. Unless specified otherwise in a contract with a party, SK does not provide notice of assignment.

9.16.3 Severability

If any provision of this CPS is held invalid or unenforceable by a competent court or tribunal, the remainder of the CPS remains valid and enforceable. Each provision of this CPS that provides for a limitation of liability, disclaimer of a warranty, or an exclusion of damages is severable and independent of any other provision.

9.16.4 Enforcement (Attorneys' Fees and Waiver of Rights)

SK may claim indemnification and attorneys' fees from a party for damages, losses, and expenses related to that party's conduct. SK's failure to enforce a provision of this CPS does not waive SK's right to enforce the same provision later or right to enforce any other provision of this CPS. To be effective, waivers must be in writing and signed by SK.

9.16.5 Force Majeure

Refer to clause 9.16.5 of SK PS [1].

9.17 Other Provisions

Not applicable.

REFERENCES

- [1] SK ID Solutions AS – Trust Services Practice Statement, published: <https://www.skidsolutions.eu/resources/trust-services-practice-statement/> ;
- [2] RFC 3647 – Request For Comments 3647, Internet X.509 Public Key Infrastructure Certificate Policy and Certification Practices Framework;
- [3] Certificate, OCSP and CRL Profile for Intermediate CA Issued by SK, published: <https://www.skidsolutions.eu/resources/profiles/> ;
- [4] Police and Border Guard Board - “Requirements for issuing and managing the EE-GovCA2018 root certificate“ (PBGB’s internal document);
- [5] eIDAS - Regulation (EU) No 910/2014 of the European Parliament and of the Council of 23 July 2014 on electronic identification and trust services for electronic transactions in the internal market and repealing Directive 1999/93/EC;
- [6] ETSI EN 319 401 Electronic Signatures and Infrastructure (ESI): General Policy Requirements for Trust Service Providers;
- [7] ETSI EN 319 411-1 Electronic Signatures and Infrastructures (ESI); Policy and Security requirements for Trust Service Providers issuing certificates; Part 1: General requirements;
- [8] ETSI EN 319 411-2 Electronic Signatures and Infrastructures (ESI); Policy and security requirements for Trust Service Providers issuing certificates; Part 2: Policy requirements for certification authorities issuing qualified certificates.